

**451009**

**PIXLIP®**

**PX200 STREBE**  
**PX200 STRUT**

**Aufbauanleitung**  
User manual



[www.pixlip.com](http://www.pixlip.com)

# PX200 STREBE

## PX200 STRUT

**Unsere PX 200 STREBE verleiht dem Rahmen Stabilität, indem sie strukturelle Verformungen des Rahmens verhindert und die Montage von Zubehör erleichtert.**

Our PX 200 STREBE adds stability to the frame by preventing structural deformation of the frame and facilitating the assembly of accessories.

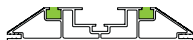

### AUSSEN NUT

#### MIDDLE GROOVE

**Es wird empfohlen, die äußere Nut zu verwenden, wenn nur eine Seite des Rahmens beleuchtet werden soll, daher sollte die Strebe auf der gegenüberliegenden Seite des zu beleuchtenden Textils installiert werden, d. h. neben dem Blockout-Textil.**

It is recommended to use the outer groove if only one side of the frame has to be illuminated, therefore the pillar should be placed on the opposite side of the textile to be illuminated, i.e. next to the blackout textile.



### MITTLERE NUT

#### CENTRAL GROOVE

**Um unerwünschte Schatten zu vermeiden, wird der Einbau der mittleren Nut empfohlen, wenn beide Textilien beleuchtet werden sollen.**

To avoid unwanted shadows, the installation of the middle groove is recommended when both textiles are to be illuminated.

# MONTAGEKOMBINATIONEN

## ASSEMBLY COMBINATIONS

Identifizieren Sie die Strukturkombination, die Ihren Bedürfnissen entspricht, und befolgen Sie die Anweisungen. Die Buchstaben unten, geben die Reihenfolge an, in der Sie die Montageanweisungen auf der gegenüberliegenden Seite befolgen sollten.

Identify the structural combination that fits your needs and follow the instructions. The letters below represent the order in which you should follow the assembly instructions on the opposite side of this page.

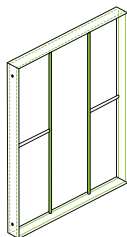
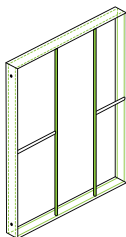
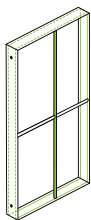
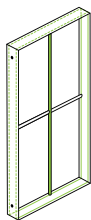
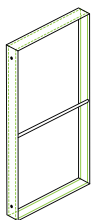
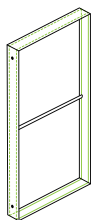

**A | B | E**

**MONTAGE IN DER ÄUSSEREN NUT**  
**MOUNTING IN THE OUTER GROOVE**

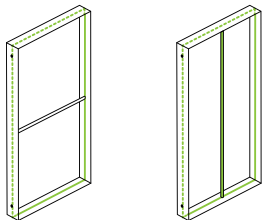

**A | C | B | D | H**

**MONTAGE IN DER MITTLEREN NUT**  
**MOUNTING IN THE MIDDLE GROOVE**

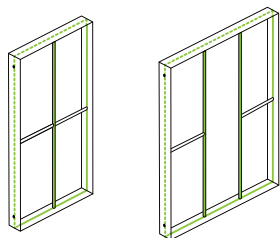

**A | C | B | D | H**

**MONTAGE IN DER MITTLEREN NUT MIT KREUZVERSTREBUNG**  
**MOUNTING IN THE MIDDLE GROOVE WITH CROSS STRUT**



**A | C | B | F**

**A | C | B | G**

# KOMPONENTEN COMPONENTS



R

**400204**



L

**400205**

## STREBENFUSS VERRIEGELUNG | STRUT FOOT LATCH

1 x Weiß R Strebenfuß Verriegelung | 1 x White R Strut foot latch

1 x Graue L Strebenfuß Verriegelung | 1 x Gray L Strut foot latch



R

**400200**



L

**400201**

## STREBENFUSS | STRUT FOOT

1 x Weiß R Strebenfuß | 1 x White R Strut foot

1 x Graue L Strebenfuß | 1 x Gray L Strut foot



R

**400202**



L

**400203**

## STREBENFUSS ADAPTER | STRUT FOOT ADAPTER

1 x Weiß R Strebenfuß Adapter | 1 x White R Strut foot Adapter

1 x Graue L Strebenfuß Adapter | 1 x Gray L Strut foot Adapter



## STREBE | STRUT

Verschiedene Mengen und Größen | Various quantities and sizes

## A | MONTAGE STREBENFUSS R ASSEMBLY OF STRUT FOOT R

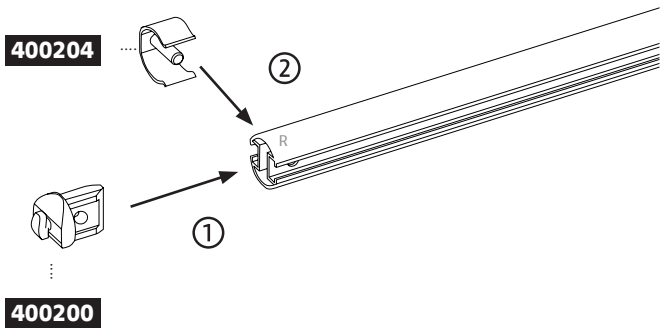

## B | MONTAGE STREBENFUSS L ASSEMBLY OF STRUT FOOT L

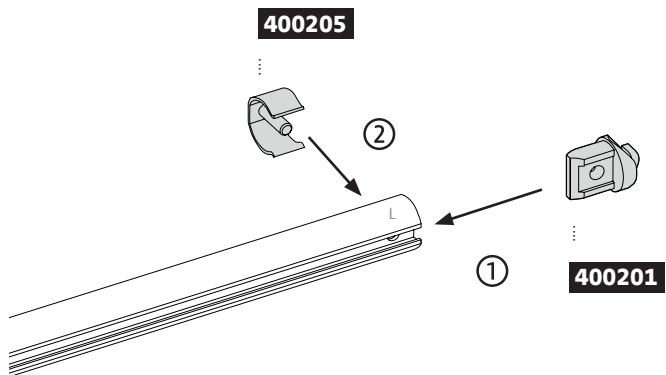

## C | MONTAGE DES ADAPTERS L AM STREBENFUSS ASSEMBLY OF THE ADAPTER L ON THE STRUT FOOT

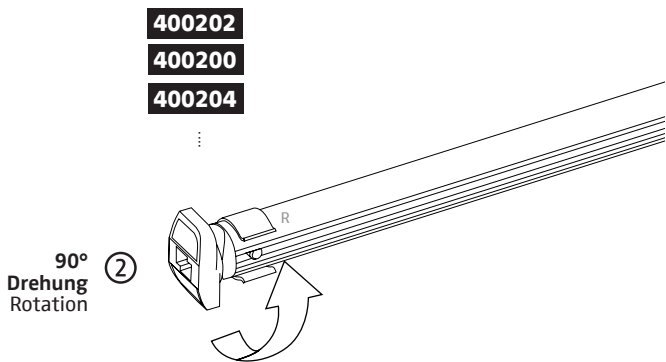
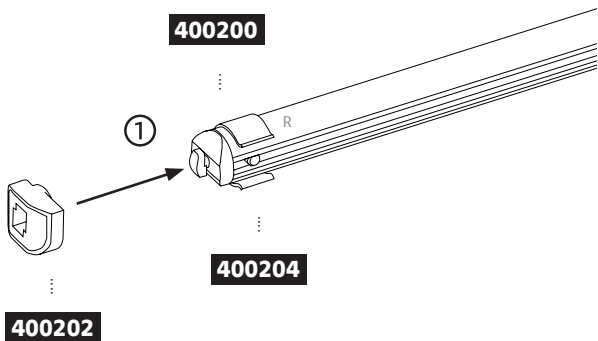

**D** | **MONTAGE DES ADAPTERS R AM STREBENFUSS**  
**ASSEMBLY OF THE ADAPTER R ON THE STRUT FOOT**

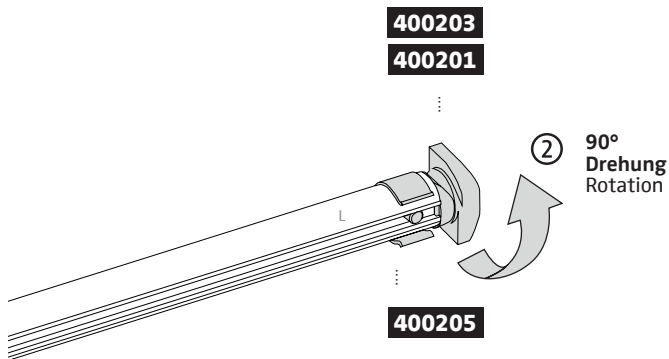
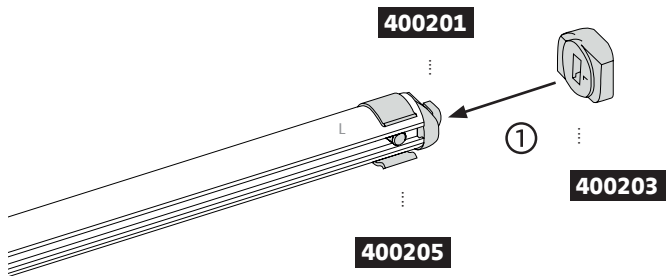



**E** | **MONTAGE AUSSEN NUT, KREUZVERSTREBUNG**  
**ASSEMBLY OF OUTER GROOVE, CROSS STRUT**

**Strebe oder Rahmen Äußere Nut**  
**Strut or frame outer groove**

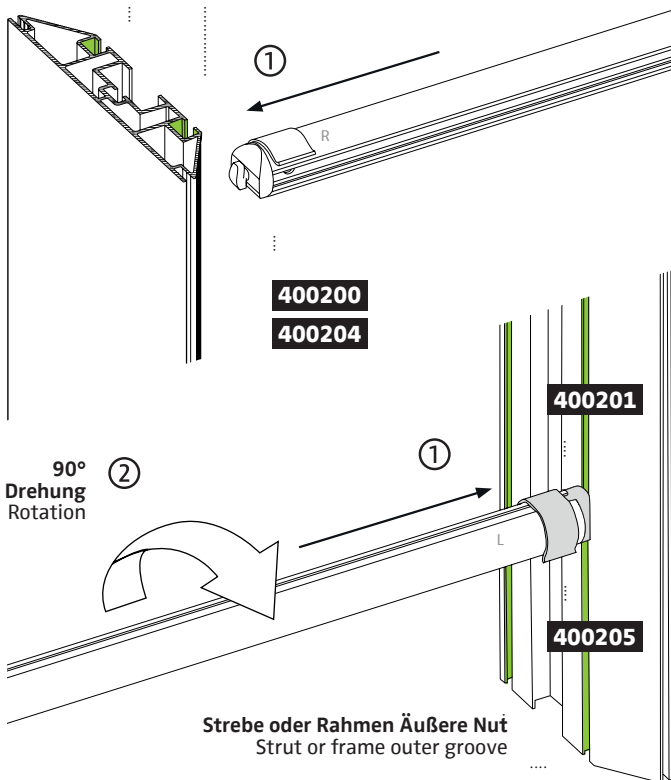

# F | MONTAGE MITTLERE NUT MIT KREUZVERSTREBUNG R ASSEMBLY OF CENTRAL GROOVE WITH CROSS STRUT R

**Rahmen mittlere Nut**  
Frame central groove

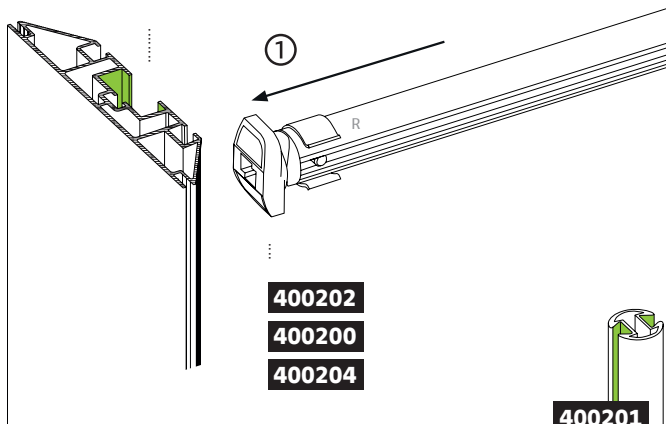

90°  
Drehung  
Rotation

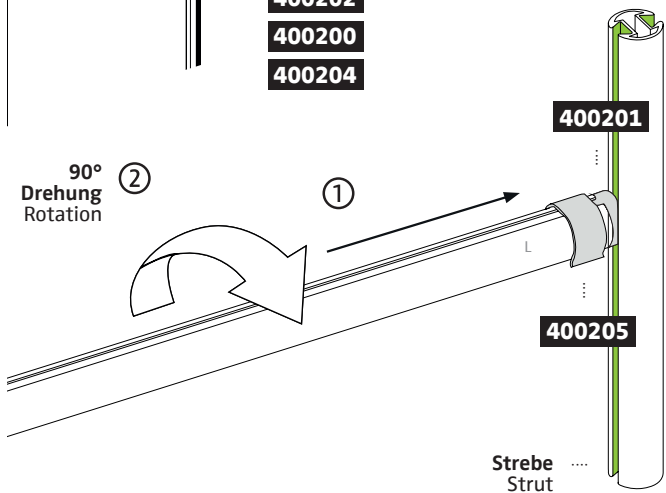

# G | MONTAGE MITTLERE NUT MIT KREUZVERSTREBUNG L ASSEMBLY OF CENTRAL GROOVE WITH CROSS STRUT L

Strebe  
Strut

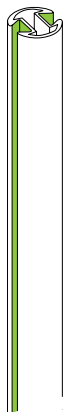

①

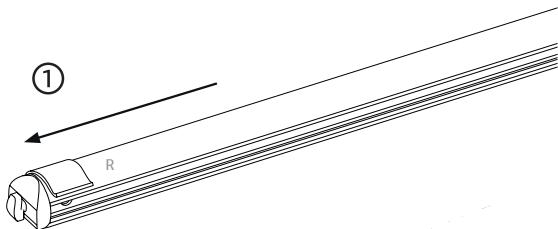

400200

400204

90°  
Drehung  
Rotation

②

①

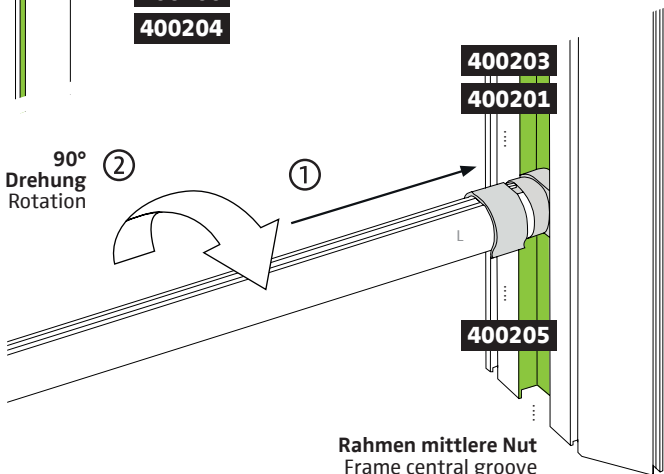

400203

400201

400205

Rahmen mittlere Nut  
Frame central groove

# H | MONTAGE MITTLERE NUT ASSEMBLY OF CENTRAL GROOVE

Rahmen mittlere Nut  
Frame central groove

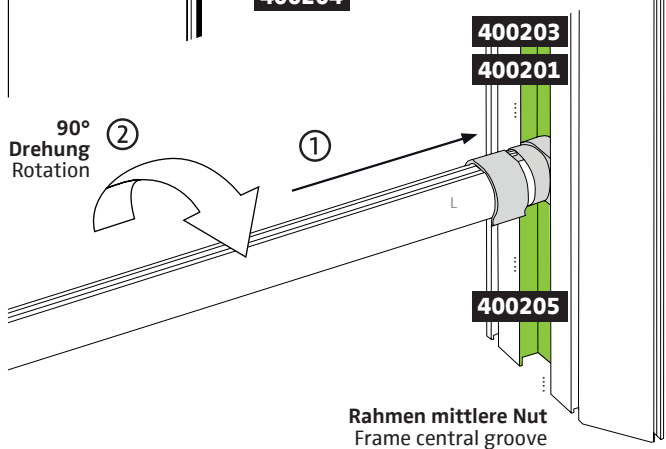
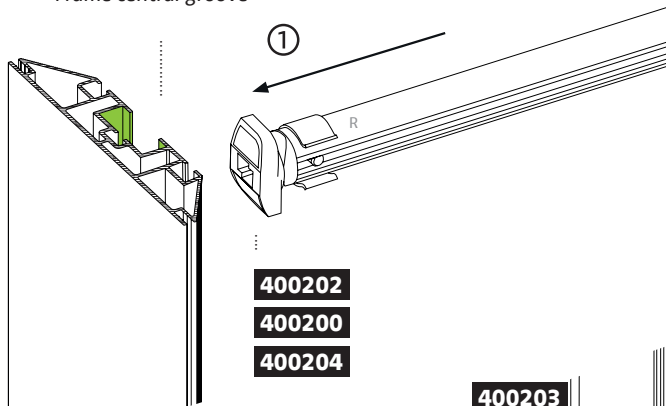

**ACHTUNG**  
**ATTENTION**



**STREBE NICHT HEBELN!**  
**DON'T LEVER THE STRUT!**

# **SICHERHEITSHINWEISE**

## **SAFETY INSTRUCTIONS**

**Lesen Sie vor der Installation und Verwendung des Produkts die mitgelieferte Anleitung sorgfältig durch. Der Hersteller haftet nicht für Verletzungen oder Schäden, die auf eine unsachgemäße Installation oder Verwendung zurückzuführen sind.**

**Bewahren Sie die Anleitung immer an einem sicheren und zugänglichen Ort auf, um sie später nachschlagen zu können. Die Montage und Installation sollte nur von geschultem Fachpersonal durchgeführt werden.**

**Bitte verwenden Sie nur die mitgelieferten Bauteile. Ein beschädigtes Produkt darf nicht installiert oder verwendet werden. Verwenden Sie zur Reinigung keine aggressiven Chemikalien oder Scheuermittel.**

Before the installation and use of the appliance, carefully read the supplied instructions. The manufacturer is not responsible for any injuries or damages that are the result of incorrect installation or usage.

Always keep the instructions in a safe and accessible location for future reference. Assembly and installation should only be carried out by trained specialist personnel.

Please only use the delivered devices. Do not install or use a damaged appliance. Do not use aggressive chemicals or abrasives for cleaning.



**MONTAGEVIDEO**  
ASSEMBLY VIDEO





# SUPPORT REQUEST

[support@pixlip.com](mailto:support@pixlip.com)



© 2021

PIXLIP GmbH  
Raiffeisenstraße 17  
40764 Langenfeld  
Deutschland | Germany

[info@pixlip.com](mailto:info@pixlip.com)  
[www.pixlip.com](http://www.pixlip.com)